

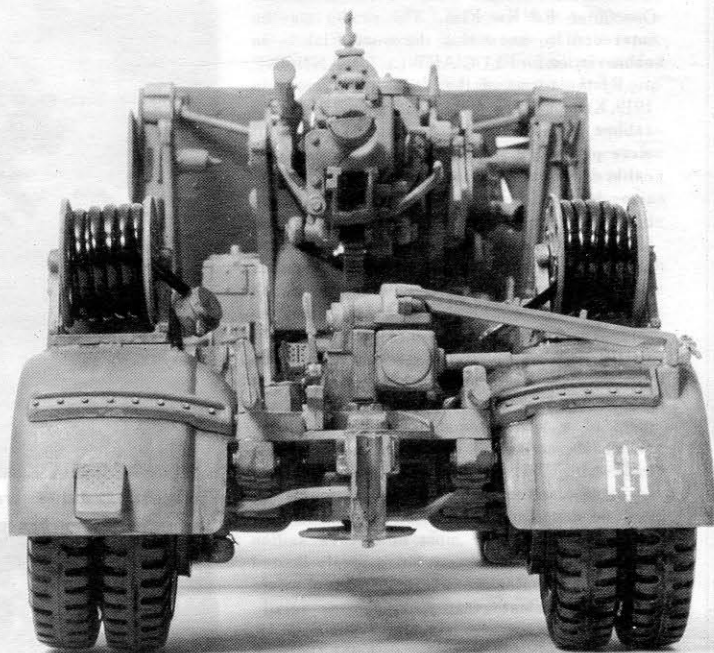

+GERMAN 88mm Gun Flak 36 / 37

1/35 MILITARY MINIATURE SERIES

ITEM 35017

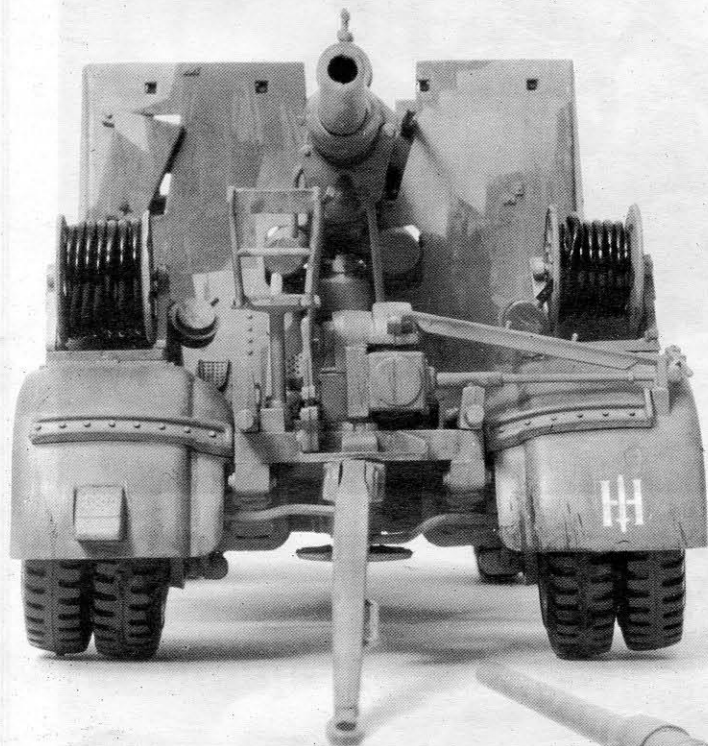

88mm Gun Flak 36/37

THE HISTORY AND ORIGINS OF THE GERMAN 88mm GUN.

This famous weapon is well known for its role in World War II. It did, in fact, have its origins during the first World War, when guns of this calibre were used in an anti aircraft role.

These guns were mounted on a 4 wheel trailers towed on specially fitted army lorries. When in action arms with jacks were swung out to form a secure firing platform. For that time these guns were extremely mobile and could swiftly be ready to fire.

The year was 1916 when these weapons entered service. They were manufactured by two factories, namely Krupps of Essen and Rheinmetall-Borsig. They were designated Geschütze 8.8 Kw Flak. The reader may be interested to know that the word Flak is an abbreviation for FLUG ABWEHR KANNONE.

By the terms of the Versailles Treaty in 1919, Krupps were forbidden to produce small calibre guns below 17 cm, and Rheinmetall were prohibited from making guns above this calibre. In order to overcome these restrictions by the Disarmament Commission, Krupp came to an agreement in 1921 with the Bofors Company in Sweden, whereby Bofors acquired the foreign rights for all Krupp gun designs in return for granting design and research facilities for Krupp's design team at the Bofors Works.

By 1928, Krupp's team, working in Sweden, had developed the plans for a new design of the 88 mm High Velocity Gun with the refinement of a semi-automatic breech which re-cocked the striker on ejection of the cartridge case. In 1931, a Krupp Designer took the finalised plans to Essen and production of the new 88 mm Gun commenced in Germany in 1933, by which time most of the Versailles Treaty Restrictions were being openly flouted by the Nazi Regime which gained absolute power in Germany that year.

The new Gun was designated 8.8 Flak 18, and was first used in action with the German-backed Nationalist Forces in the Spanish Civil War, 1936-39, where it was mainly employed in the anti-aircraft role for which it was designed. The Flak 18 was carried on a cruciform mounting with a wheeled bogie fore and aft for towing. Before firing it had to be lowered from the bogies and emplaced. Battle experience in Spain showed the need for a reduction in time taken to get the weapon into action, and provision for barrel changing after prolonged fire.

In 1936-37, therefore, improvements were made on the basic design, and the revised model, the 8.8 Flak 36, had a multi-section interchangeable barrel and a new trailer/mounting, designated Sonderanhaenger 201, with an improved cruciform platform and a simpler method of lowering it for emplacement.

Lowering was effected by unwinding the winches on the two bogie/limber assemblies so that they tilted and thus lowered the platform to the ground. The bogie/limber assemblies were then wheeled clear and the cruciform side arms lowered. The mounting was levelled via the jacks on the end of each arm of the cruciform and spikes driven through the arms into the ground completed the emplacement of the weapon.

Most important improvement with the Sonderanhaenger 201, however, was the facility for firing the gun at low angle against ground targets without the need for lowering the mounting to the ground. For firing from the

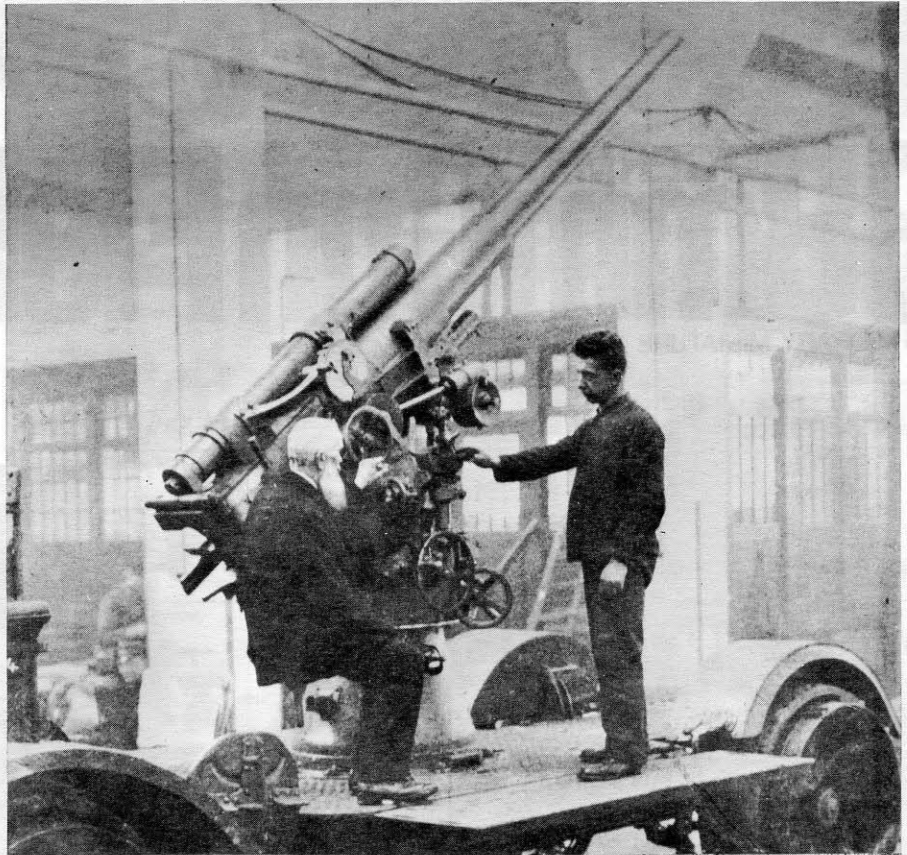

Early 88mm Anti-Aircraft Gun, 1917

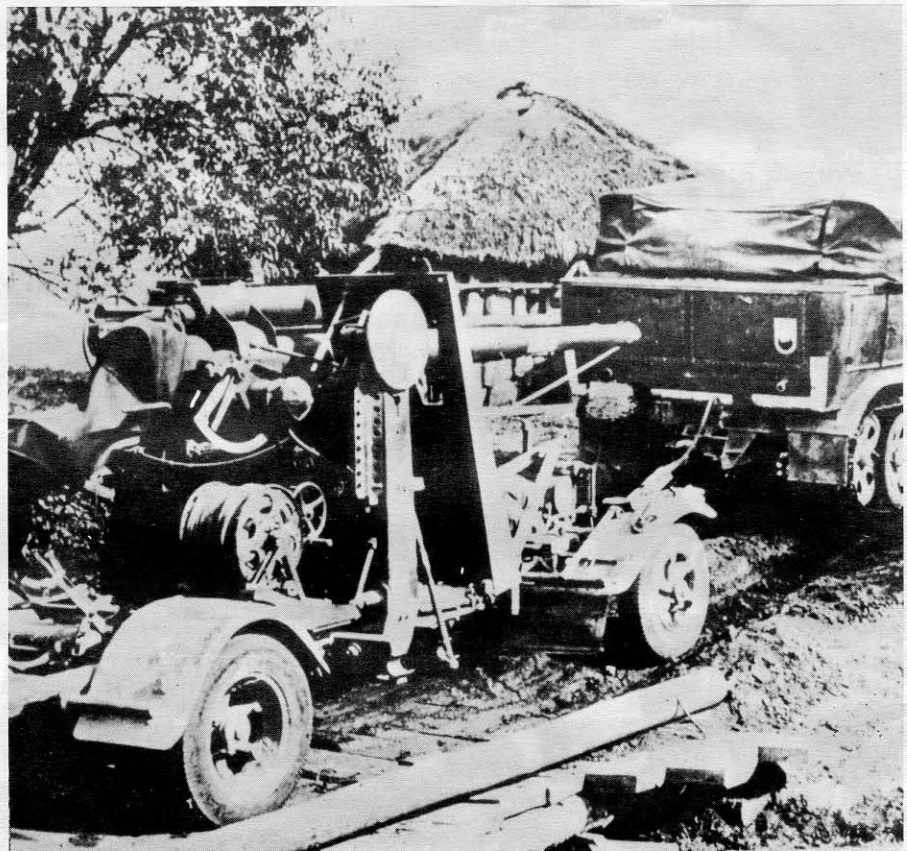

Flak 18 and 8ton Semi Track, in France 1940

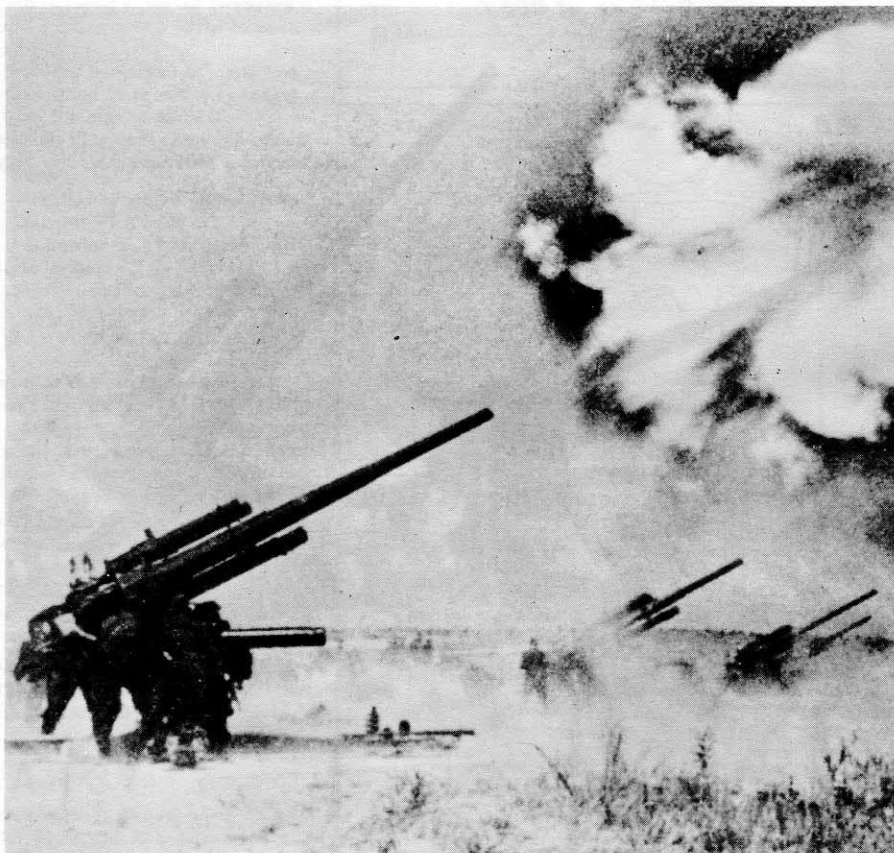
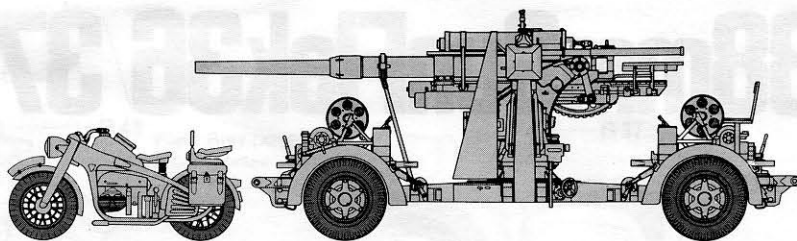

88 mm Gun Flak 18



Flak 18 in action at Sidi Rezeg in Libya

travelling position, the side arms of the cruciform were lowered, the wheel brakes were applied by hand on the rear trailer, and chocks were placed behind the wheels. From 1938, many Flak 18s were retrospectively fitted on the Sonderanhaenger 201, and 50 of these were further modified so that one man could lay the gun for both line and elevation, though this feature was not continued.

From 1940 onwards both the Flak 18 and Flak 36 on the Sonderanhaenger (Trailer) 201 were fitted with shields to give the crew protection when firing at ground targets. Late models of the Flak 36 were fitted with an improved trailer mounting, the Sonderanhaenger 202, which was fitted with twin wheels. The towing vehicle used for both Flak 18 and Flak 36 was the Sd.Kfz 7 Tractor, built by Krauss-Maffei. This well known type of half track vehicle had seating for the gun crew and lockers at the rear for ammunition and equipment.

A similar weapon to the Flak 36 was the Flak 37 which was specifically produced for the anti aircraft role, and was fitted with a new data transmission system known as Übertragungser 37, suitable only for high angle engagements.

Both the Flak 18 and Flak 36 had a high angle range of 35,100 ft. and a horizontal range of 16,200 yards. They could fire high explosive (HE), armour piercing (AP) or smoke shells. The weight of the projectile was 20 lbs. (HE) or 21 lbs. (AP and smoke). Muzzle velocity was 2690 ft. per second with HE and 2620 ft. with AP.

In travelling order on the special trailer 201, the Flak 18 and 36 weighed 7 tons. Rate of fire was 15–20 rounds per minute.

The crew was 11 men, consisting of layer, trainer, breechworker, fuse setter, and five ammunition supply numbers, plus the detachment commander and the tractor driver. When firing against ground targets two ammunition numbers became the range and deflection setters respectively, and the fuse setter became an ammunition number. The senior ammunition number was in charge of ammunition supply and was the detachment second-in-command.

There were three methods of fire control, by radar or predictor through a data transmission system for AA fire, direct laying through the sights for the anti-tank role, and indirect fire in conjunction with a range-finder.

Flak 36s made their debut in the notorious anti-tank role at Halfaya during the Battle of Sollum, June 1941. Firing from concealed positions at short range, they destroyed 123 out of 238 attacking British tanks. The Germans claimed one British tank for every 20 "88" rounds fired at Halfaya.

The Flak 18 and Flak 36 models were produced in by far the greatest numbers of all the 8.8 series of guns. However, there were several important derivatives, less well-known now because the war situation when they appeared restricted production, and they were less often seen in action.

Most important of all was the 8.8 cm Flak 41, developed and produced by Rheinmetall-Borsig as a true multi-purpose anti-tank/anti-aircraft weapon. It overcame the inherent disadvantage of the Flak 18 and 36 in the anti-tank role—the great height of the mounting—by virtually turning the upright mount arrangement of the earlier models through 90 degrees to reduce the silhouette.

The barrel was lengthened and strength-

88mm Gun Flak 36/37

ened, and the muzzle velocity increased to 3,110 feet per second. Rate of fire was about 20 rounds per minute. The gun could be fired from the travelling position with the cruciform side arms extended, and the twin-wheeled Sonderanhaenger 202 was standard with this weapon. The cruciform was wider than that of the Flak 36. The Flak 41 entered service in 1943 and saw some service in the last stages of the North Africa campaign.

Krupp had been developing a similar multi-purpose 8.8 cm gun, but the Rheinmetall design, the Flak 41, was ready first, so it was decided to keep the Krupp model specifically as an anti-tank (Pak) and tank gun, since the use of the "88" in the anti-tank role in the desert and on the Russian Front had shown the desirability for a purpose-designed weapon of this calibre. Designated Pak 43, the Krupp gun had a muzzle brake and was mounted on a field platform transported on single-wheel bogies similar to those of the Sonderanhaenger 201. This weapon was lower than the Flak 41 but, of course, lacked high angle elevation. The gun could be either lowered and emplaced for firing or it could be fired from the travelling position so long as the traverse was kept within 30 degrees either side of the longitudinal girders of the field platform. The barrel of the Pak 43 was 21 feet 7 1/4 inches long and the muzzle velocity with AP40 shot was 3,705 feet per second. With APCBC, the MV was 3,280 fps, and with HE, the MV was 2,460 frps. With APCBC, it could penetrate 130 mm of armour at 1,500 yards. This weapon entered service also in 1943.

Due to the urgency of the war situation at this time—and the scarcity of materials—many of the Pak pieces were mounted on a single axle field carriage, in which guise they were designated Pak 43/41. The carriage was of the split trail type and was of composite construction. The trail legs were the type used on the carriage of the 10.5 cm Model 18 howitzer and the solid disc wheels were of the type used with the 15 cm medium field howitzer. Weight of this weapon was 9,600 lbs.

The tank and panzerjager guns in the 88 mm series had approximately the same performance, and fired the same ammunition as the Pak 43 and Pak 43/41. Some of the barrels were of the monobloc piece construction, others of the divided monobloc barrel type. The third model was also a divided monobloc barrel construction but the length of the rifling was increased. This was the gun that formed the armament of the Royal Tiger, Elefant Panzerjager and the Jagd Panther.



Flak 18 (Right) and Flak 36 (Left), Note the difference of Barrel



Destroyed Flak 37

8.8 cm KwK 36 L/56.

Overall Length including muzzle brake:
17 ft. 15 1/2 in.

APCBC Shell: 21 lb.	MV 2,600 fps.
AP40 Shot: 16 lb.	MV 3,070 fps.
HE Shell: 20 lb.	MV 2,690 fps.

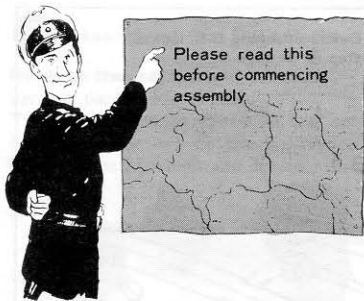

Please read this before commencing assembly

★You will required a pair of tweezers, a file and a sharp hobby knife to build your kit.

★As this kit is composed of many fine parts, take good care when removing parts from the plastic sprues.

★Always use glue very sparingly. Too much glue will spoil your finished model.

There were two types of 88mm Gun: FLAK 36 and FLAK 37

From the contents of this kit you may build either.

FLAK 36 : used as an anti-tank gun.

FLAK 37 : used as an anti-aircraft gun.

Before starting to build your kit, you must decide which you are to build. Almost all of parts supplied in this kit are common to the two types, but obviously some parts differ. These different parts are shown in the diagrams by indication of the corresponding numbers, 36 and 37. Take good care to assemble the correct parts for the type you choose beforehand.

FLAK 36

36 : This number shows parts to be used for FLAK 36 Anti-tank Gun.

FLAK 37

37 : This number shows parts to be used for FLAK 37 Anti-aircraft Gun.

 This mark shows in which colour to be painted.

1 Assembly of Zündapp Motorcycle

88mm gun is composed of many detailed fine parts. Assemble Zündapp Motorcycle first, and then you will get hands of assembling fine parts.



Tamiya Acrylic Paints
Need precise colour matching?
Try the new Tamiya acrylic paints. Engineered by modelers for modeler's use. The final cover for the finest models. Insist on Tamiya for perfect results.

1 Assembly of Zündapp Motorcycle

1 Assembly of Front Fork

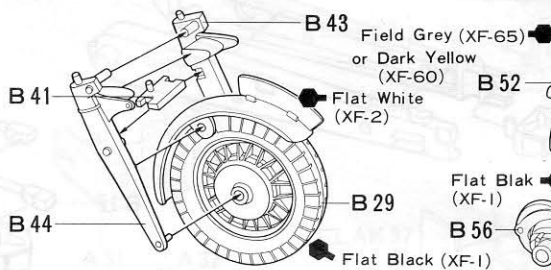

2 Assembly of Body

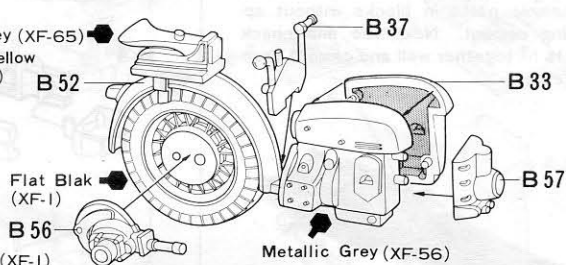

3 Assembly of Main Frame

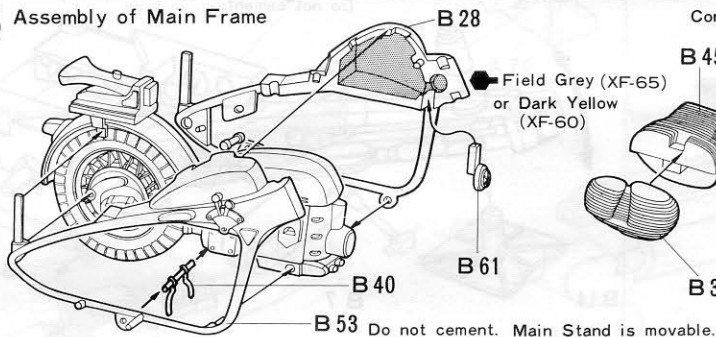

Construction of Cylinder

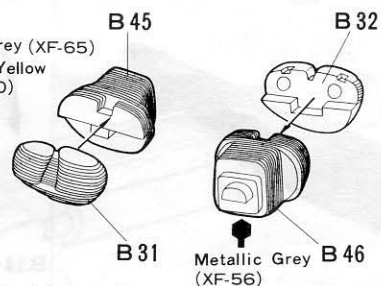

4 Installation of Parts

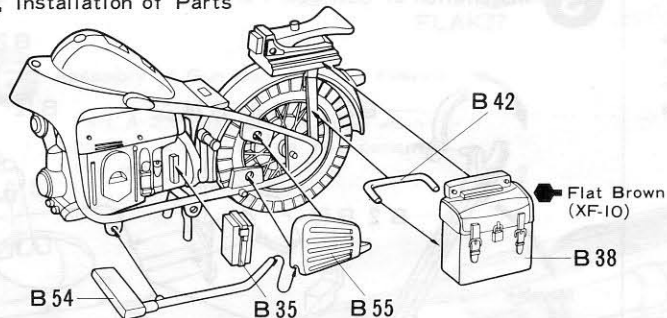

Reference Figure of Fixing of Side Bag

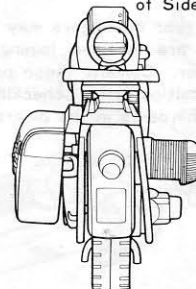

5 Installation of Cylinder

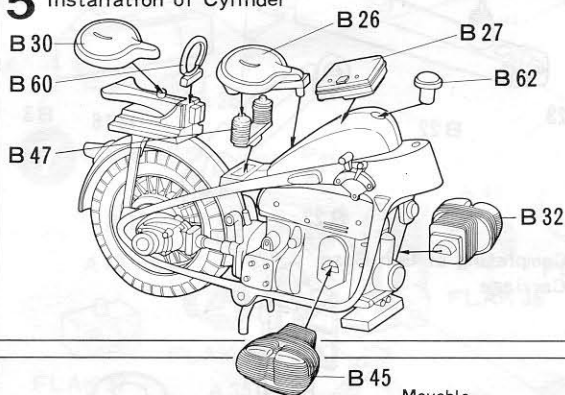

Fixing of Number Plate

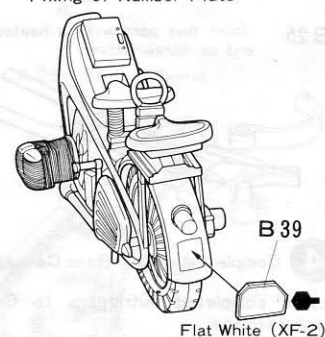

6 Construction of Zündapp Motorcycle

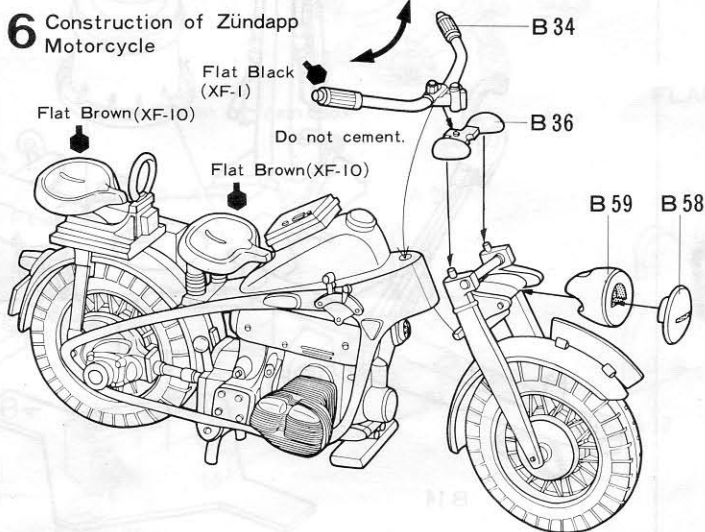

Construction of Motorcycle Soldier

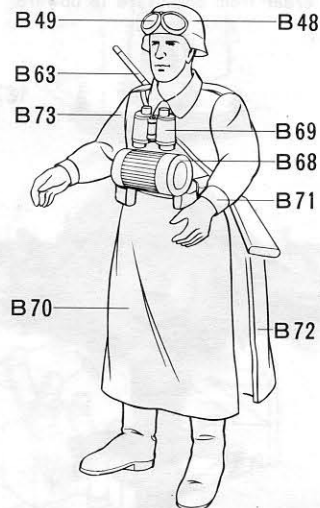

2 Assembly of Outriggers

Right and left outriggers may be folded. Do not cement movable parts. Refer to the diagram and temporarily assemble parts in blocks without applying cement. Next, see and check parts fit together well and cement them together.

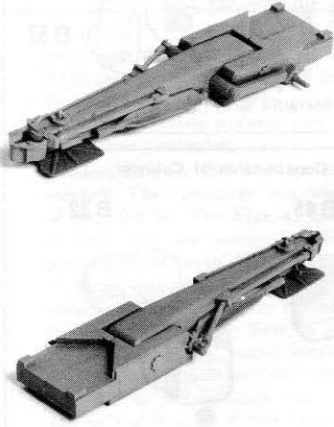

3 Installation of Outrigger Parts

Front and rear outriggers may not be folded, but are to have joining parts for a carrier. Cement these parts in correct position after checking the shape of the parts in the diagram.

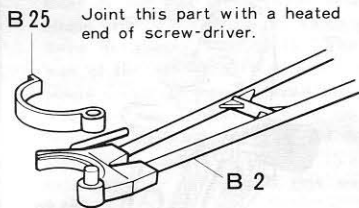

4 Completing of Gun Base Carriage

Install completed outriggers to Gun base carriage. The upper part of Gun base is composed of many fine parts. It is easier to assemble these parts if you do this in order from downward to upward.

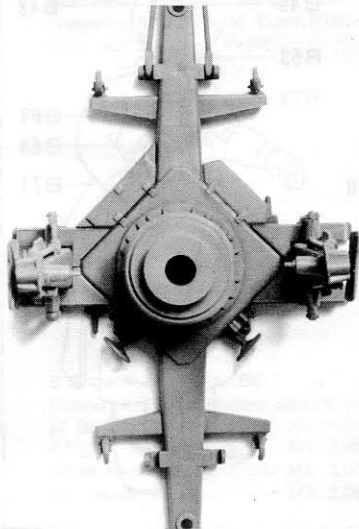

2 Assembly of Outriggers

Before attaching B-5, look at step 1 on page 9.

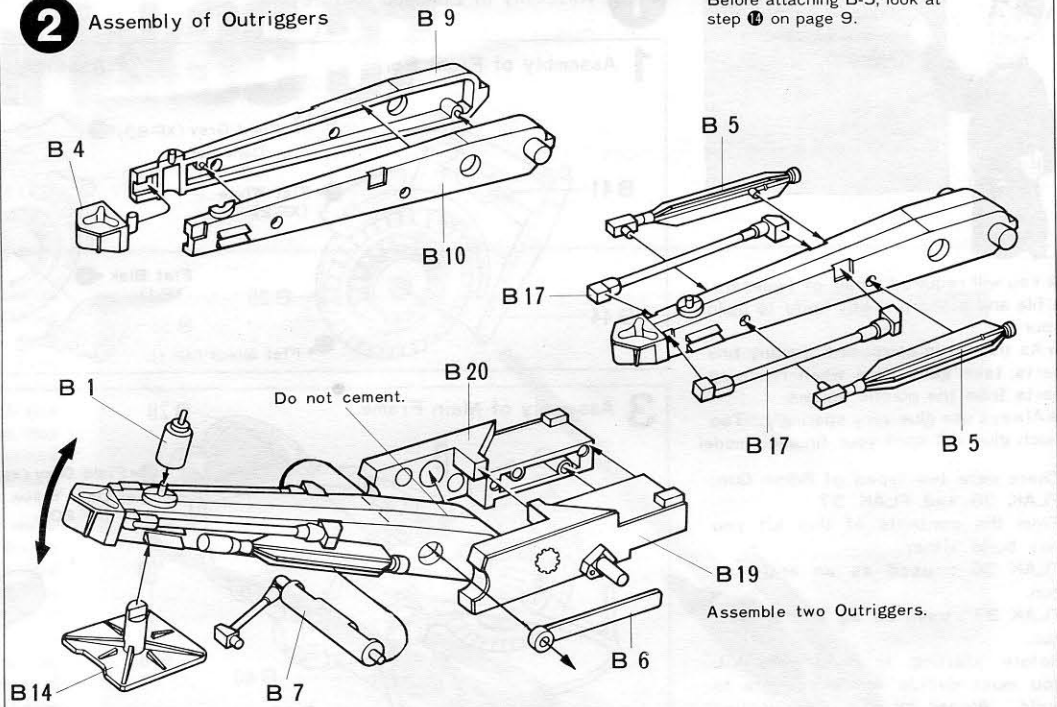

3 Installation of Outrigger Parts

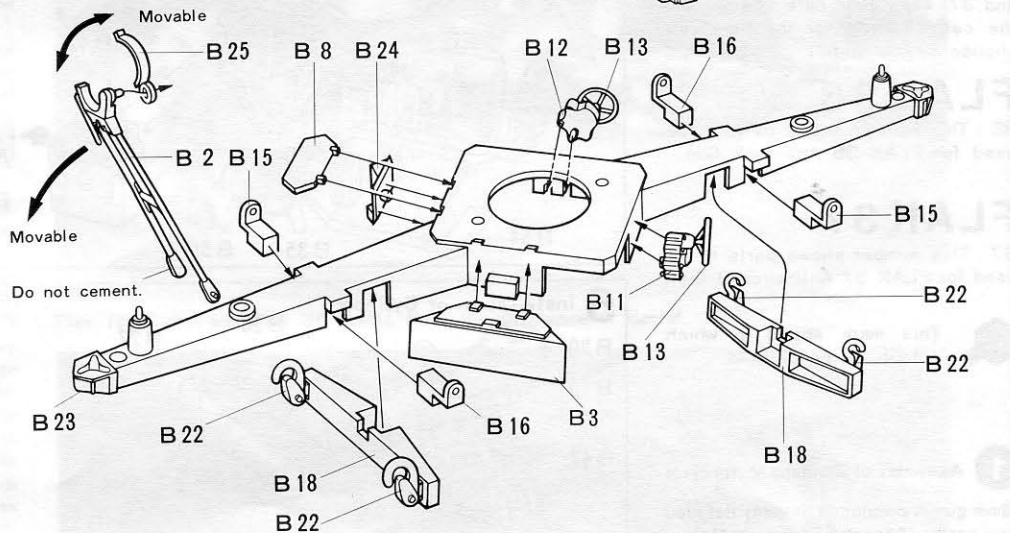

4 Completing of Gun Base Carriage

Fix part B 21 last.

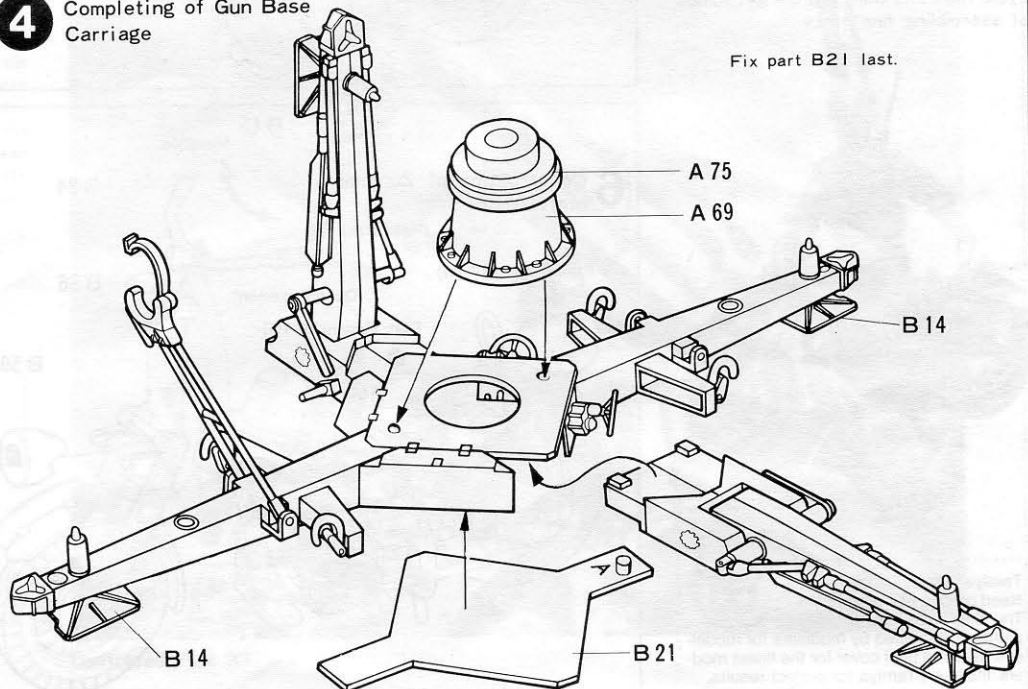

5 Assembly of Gun Base Parts

Refer to the diagram and assemble various parts beforehand. Take good care to assemble the correct parts for one of the two types, FLAK 36 or 37, which you are to make.

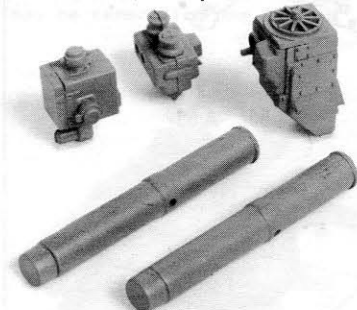

Parts A-19 and A-48 are each of different length. When gun is set at high angle, use longer part A-19. On the other hand, when gun is set at zero angle, use shorter part A-48. These parts are interchangeable according to your imaginative "combat scenes" and then do not cement either of them.



6 Assembly of Gun Barrel

Cement halves of gun barrel together. After cement has dried, scrape off surplus cement on gun barrel to make it as beautiful as possible.



7 Assembly of Top Carriage

Install various parts onto right and left side plates. Cement only right side plate to main box after fixing reciperator holder and battery case to main box.

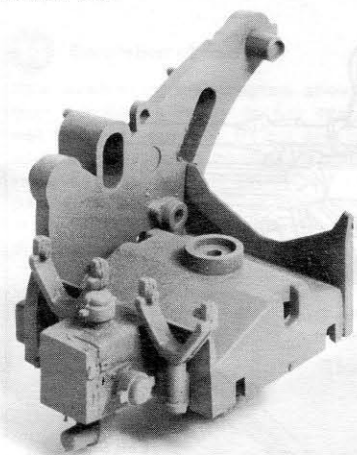

5 Assembly of Gun Base Parts

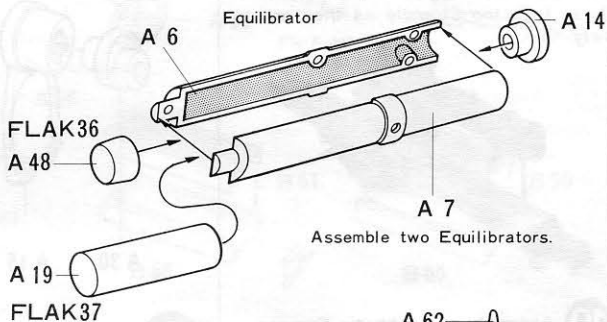
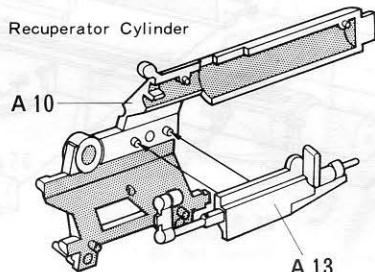
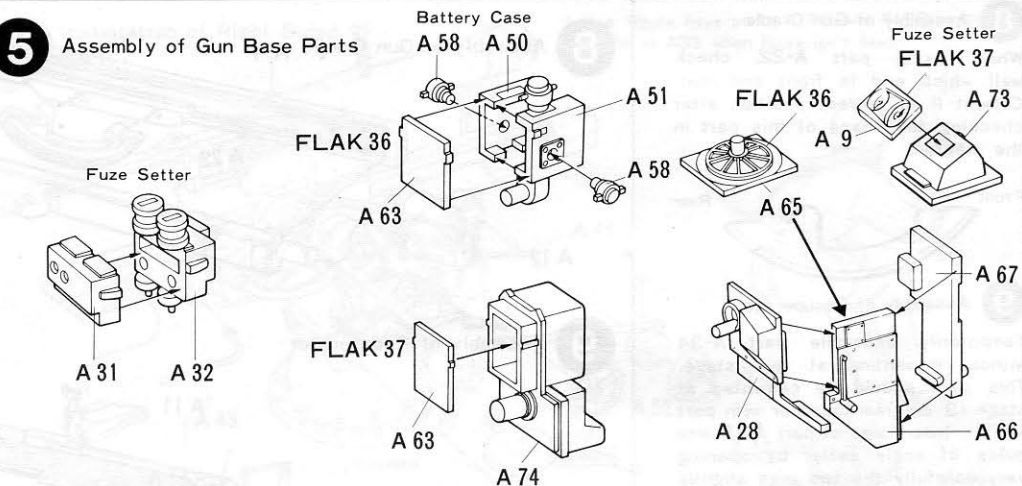

6 Assembly of Gun Barrel

Part A-23 must be set open when loading shells, so do not cement this part.

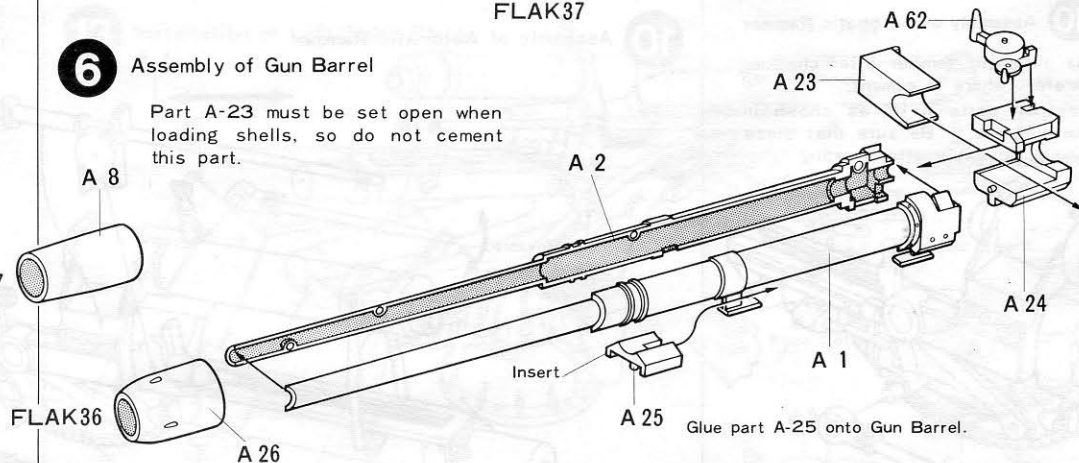

7 Fixing of Side Plate Parts

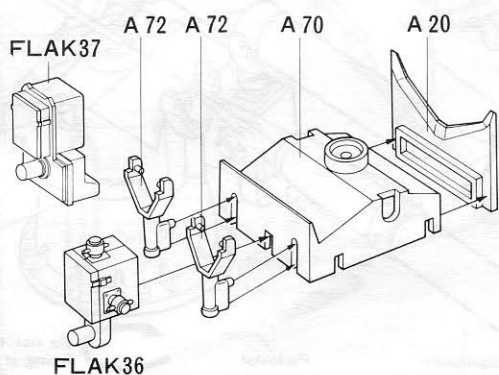
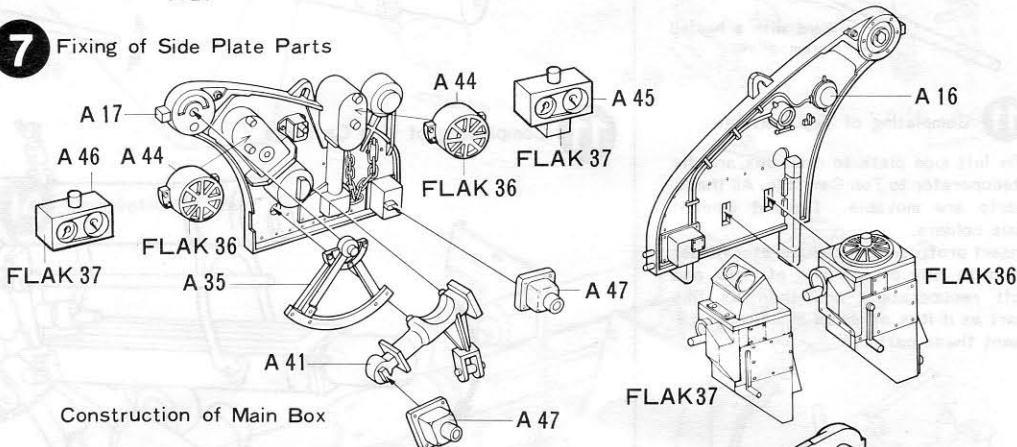

TAMIYA COLOR CATALOGUE

The latest in cars, boats, tanks and ships. Motorized, radio controlled and museum quality models are all shown in full color in Tamiya's latest catalogue. At your nearest hobby supply house.

8 Assembly of Gun Cradle

When fixing part A-22, check well which end is front and rear. Cement it in correct position after checking the shape of this part in the diagram.



9 Assembly of Recuperator

Temporarily assemble part A-34 without cementing at this stage. This part should be cemented at stage 13 diagram together with part A-37. Insert legs of part A-15 into holes of angle setter by opening very carefully the two legs slightly outward with fingers. Do not open these legs too strongly as they are very thin.



10 Assembly of Automatic Rammer

Fix automatic rammer after checking carefully where to cement. Heat-fix parts A-18 as shown in the diagram. Be sure that these remain moveable after heating.

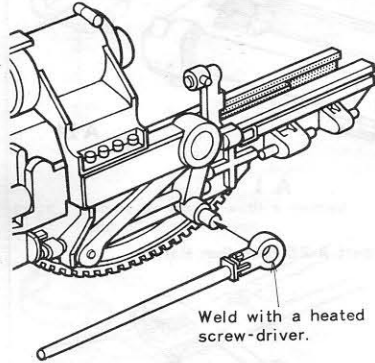

11 Completing of Top Carriage

Fix left side plate to main box, and fix Recuperator to Top Carriage. All these parts are moveable. Do not cement axis holders. Insert protrusion of recuperator holder through hole of one end of right and left recuperators, and then fix this part as if it is screwed in. Do not cement these parts.

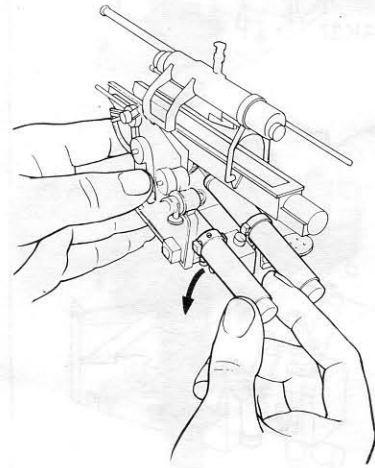

8 Assembly of Gun Cradle A 4

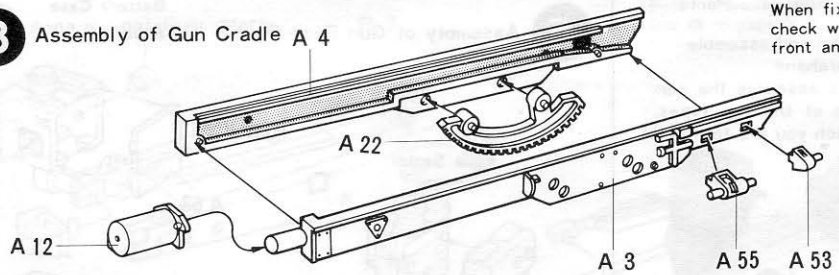

9 Assembly of Recuperator

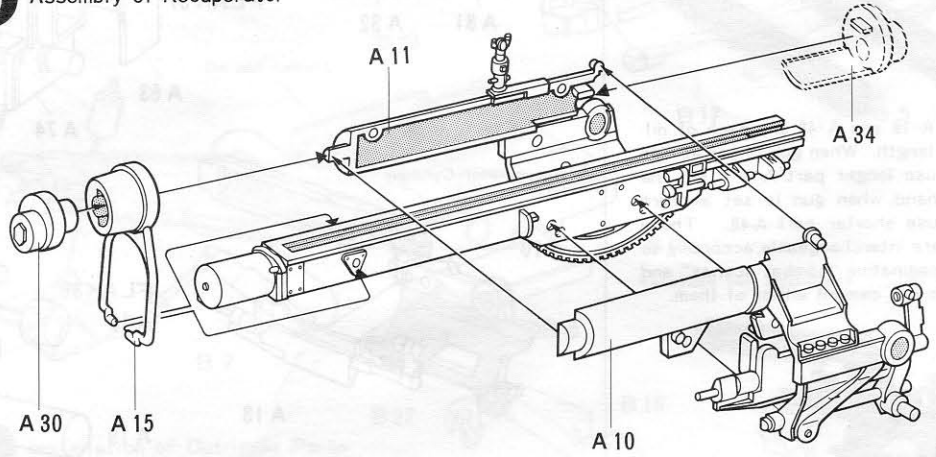

10 Assembly of Automatic Rammer

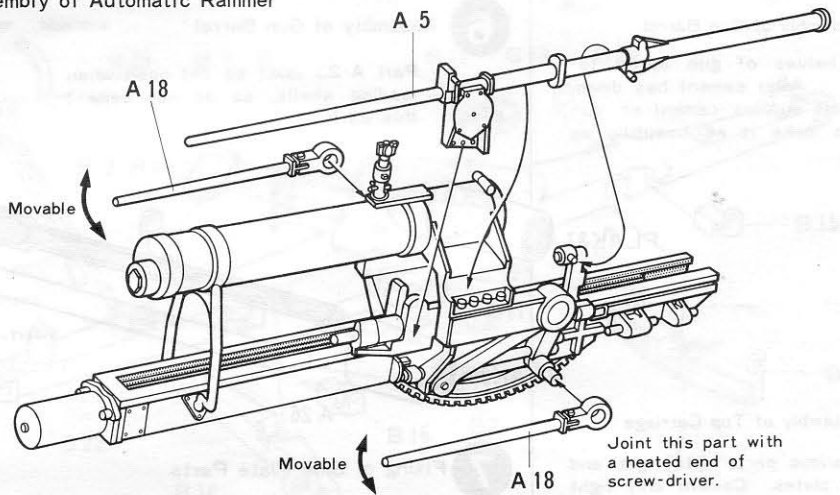

11 Completing of Top Carriage

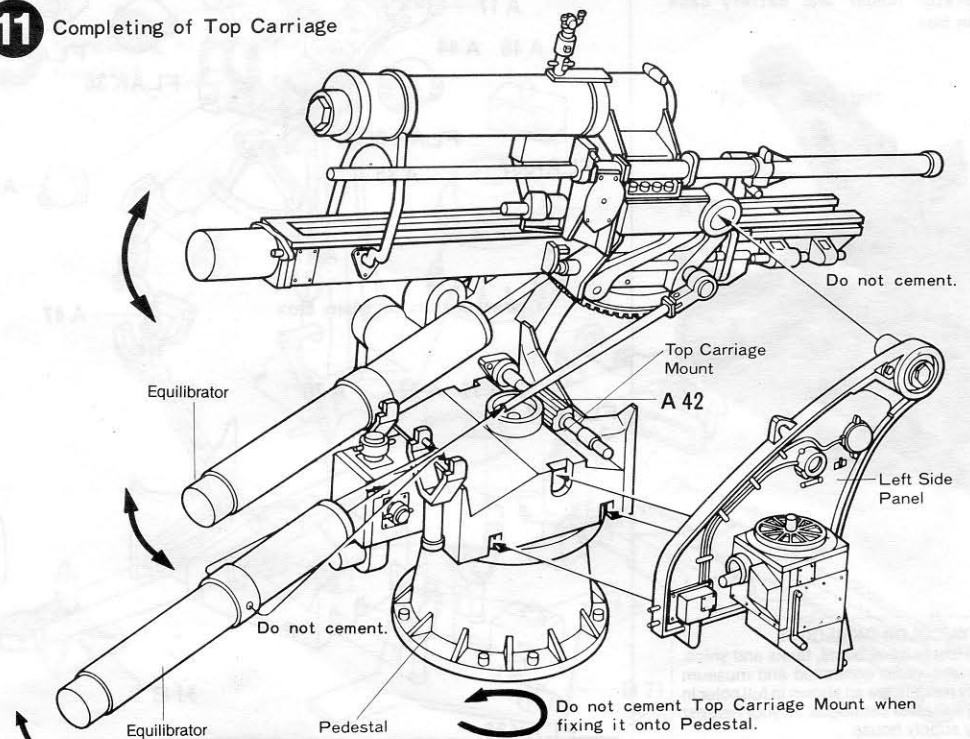

12 Installation of Right Sided Parts

Install Telescopic sight A-56, and at the same time, fix the Gunner figure. The gunner's chair is folded when in travel. If you prefer to have gunner in firing position, he may be cemented to the seat.

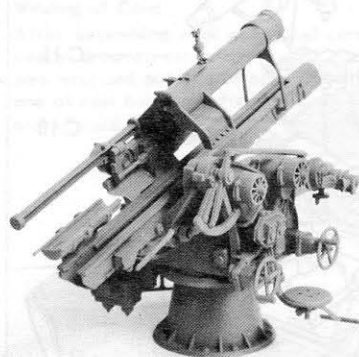

Assemble three Round Containers.

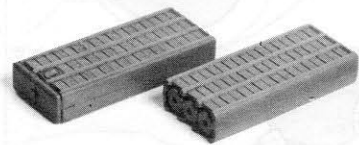

13 Installation of Left Sided Parts

Part A-71 is removed while actual firing is done. Insert this part from the underside of your model.

Do not cement Gun Shield (A-76) as this should be easily removable.



14 Completion of Gun

The sketch in the diagram shows that the gun is ready to fire against tanks or aircraft. If you are to use your completed model in a diorama setting, cut off lower half of part B-5, and put it into right position of Outrigger as shown in the diagram.

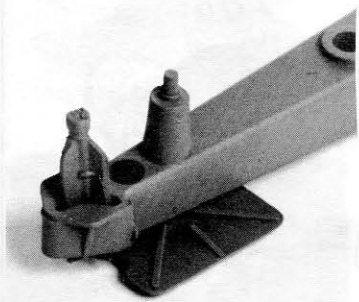

12 Installation of Right Sided Parts

Let a figure have parts A-52 and A-56 properly. Fix A56 to A33, when figure isn't fixed.

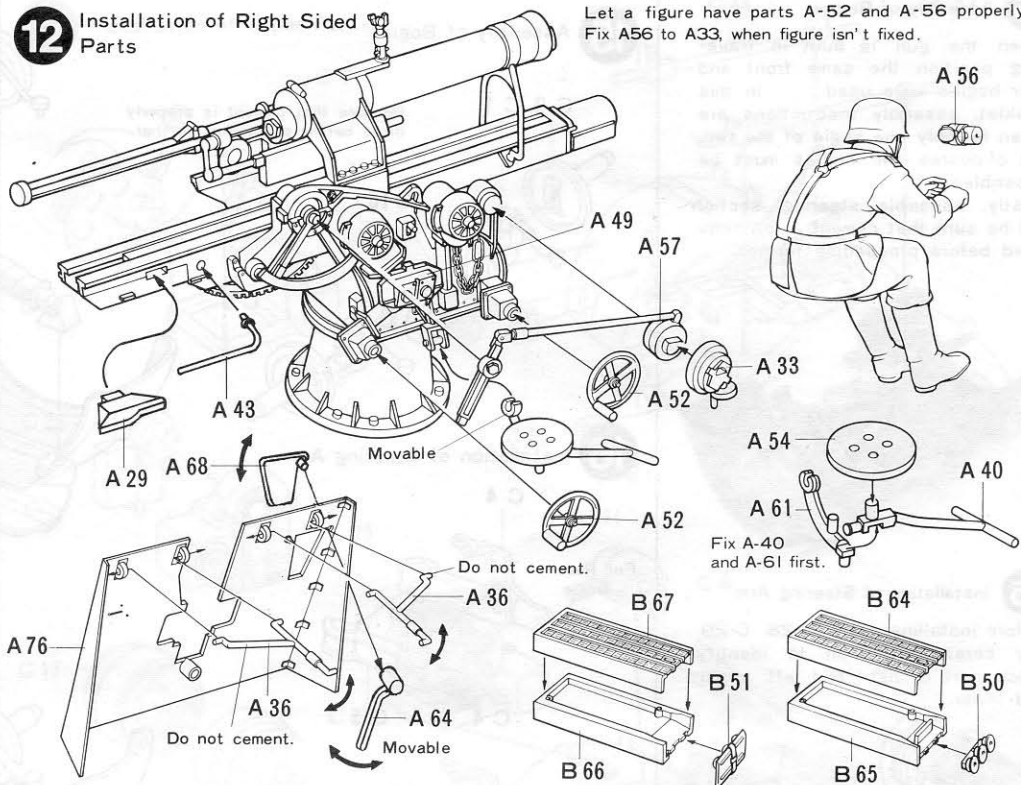

13 Installation of Left Sided Parts

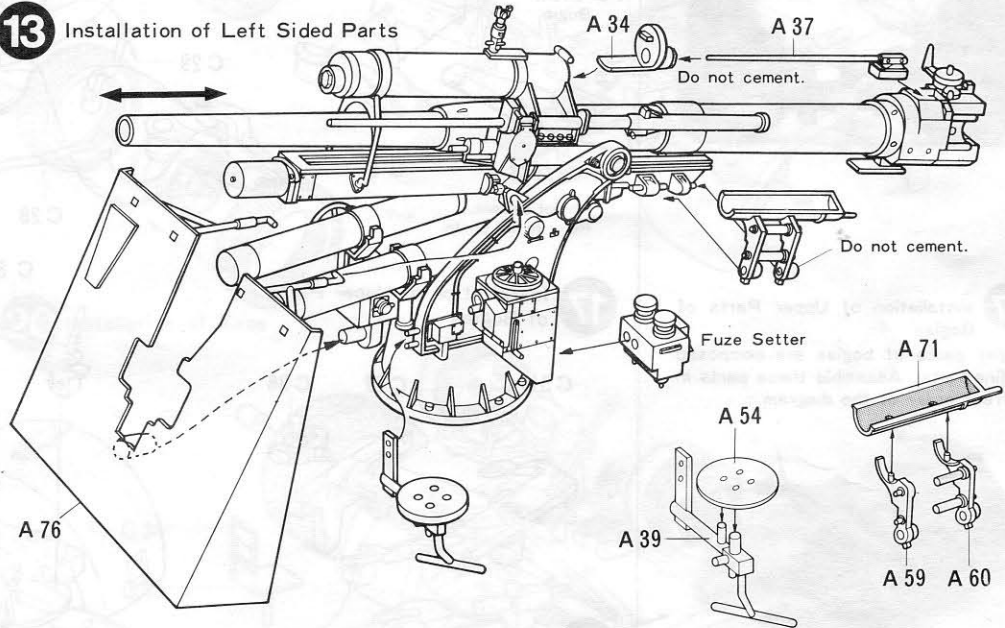

14 Completion of Gun

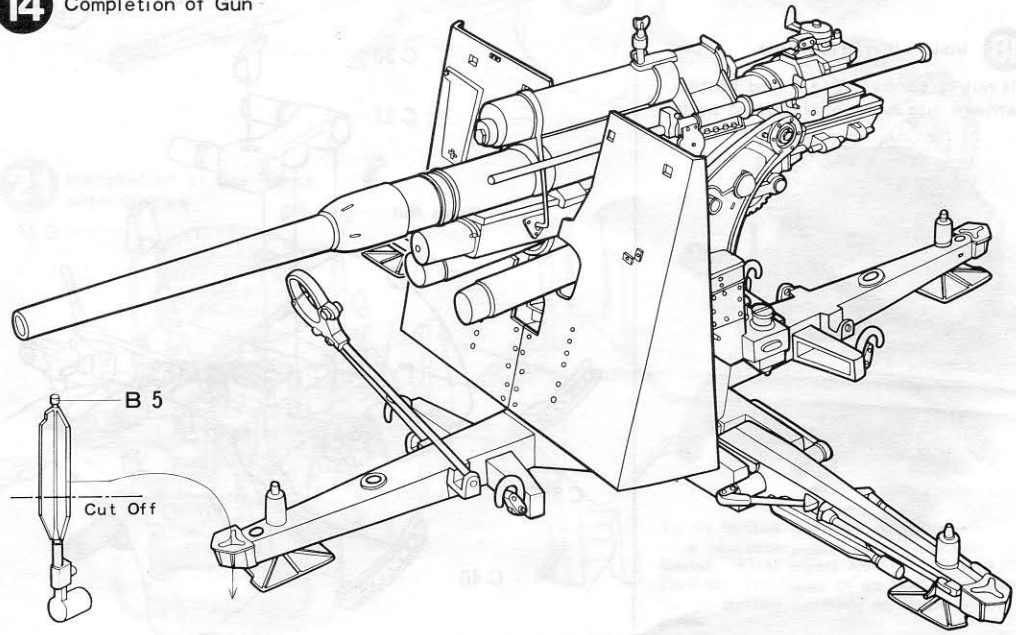

15 Assembly of Bogies

When the gun is built in travelling position the same front and rear bogies were used. In this booklet, assembly instructions are given for only one bogie of the two, but of course two bogies must be assembled.

Firstly, assemble steering section but be sure that cement is properly dried before proceeding further.

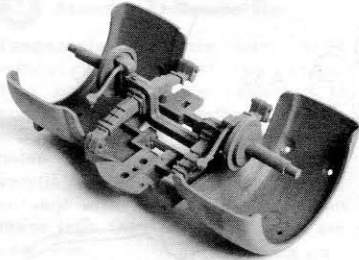

16 Installation of Steering Arm

Before installing parts C-28, C-29, pay careful attention to identify which part is right and left, upper and lower.

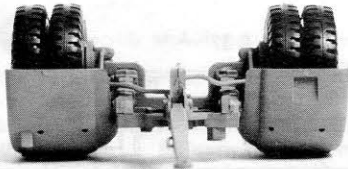

17 Installation of Upper Parts of Bogies

Upper parts of bogies are composed of fine parts. Assemble these parts in correct order of the diagram.

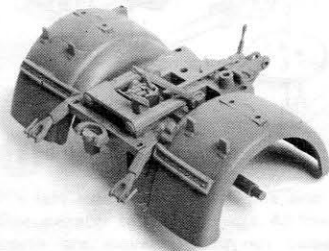

18 Installation of Cylinder

Fit nut to connect bogie and bottom carriage into hexagonal hole of part.

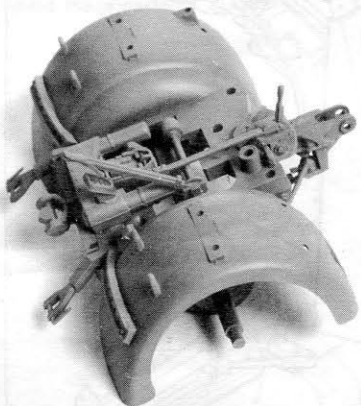

15 Assembly of Bogies

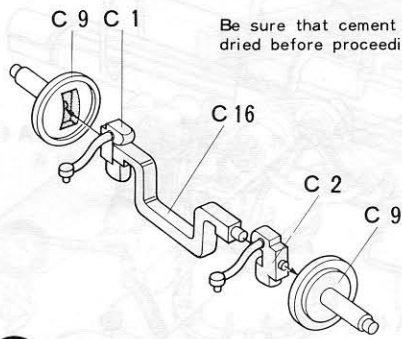

Be sure that cement is properly dried before proceeding further.

16 Installation of Steering Arm

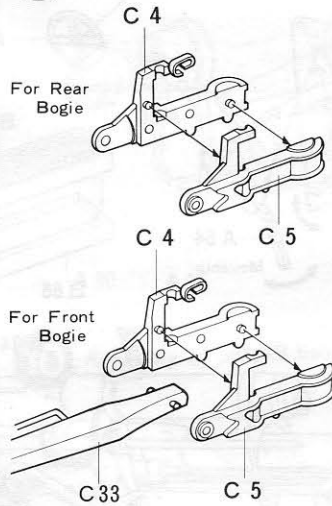

Do not cement. Refer to left photo.

17 Installation of Upper Parts of Bogies

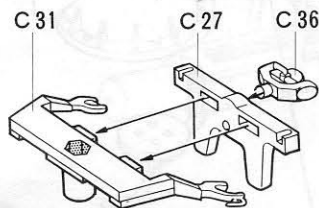

18 Installation of Cylinder

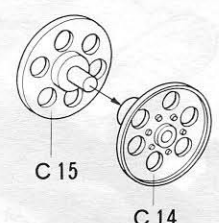
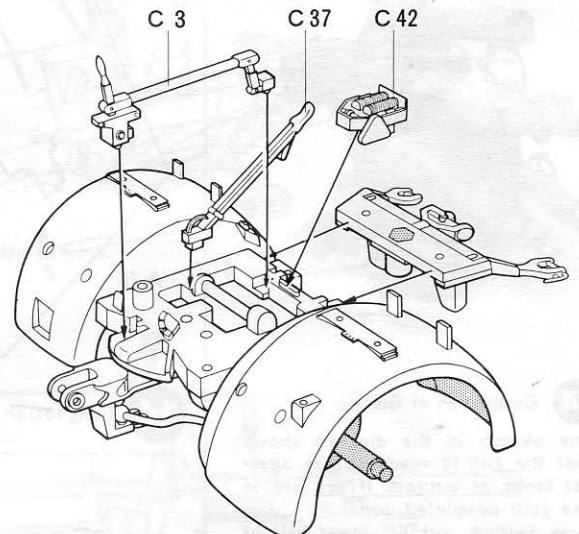
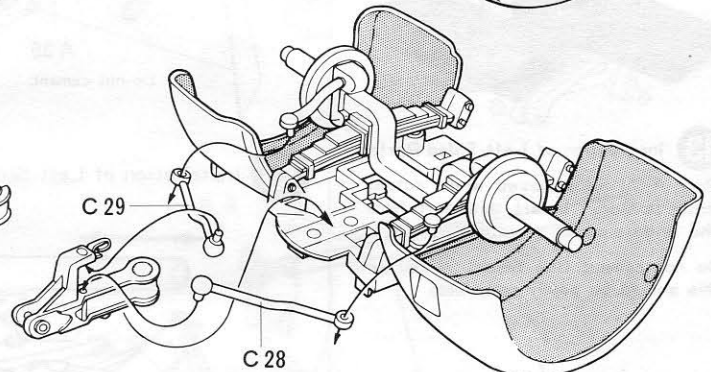
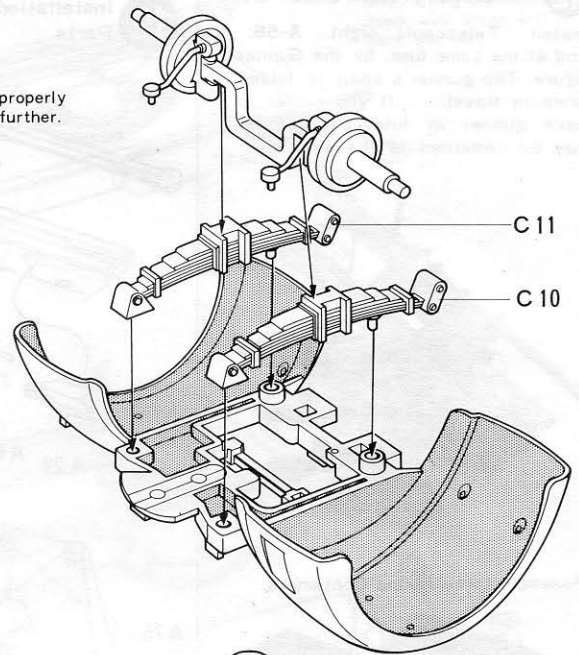
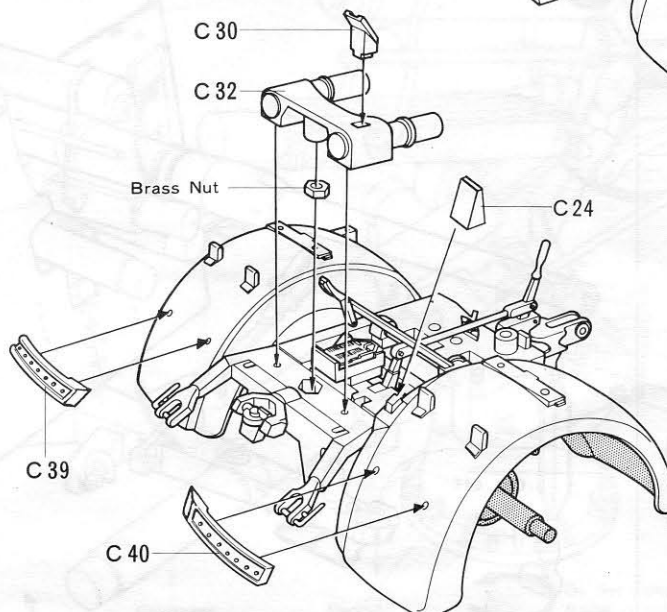

Assemble two pairs of front and rear Reels.

19 Installation of Upper Parts

Wind 1 meter of vinyl cord around Communication reel. The sketch in diagram shows that vinyl cord is cemented, but you may leave vinyl cord suspended as it looks more as if it has been used this way.

Winding of Cord

After assembling reel, wind vinyl cord neatly around reel. After vinyl cord was wound, put end of cord through one of reel holes and fix part C-19 to end of cord.

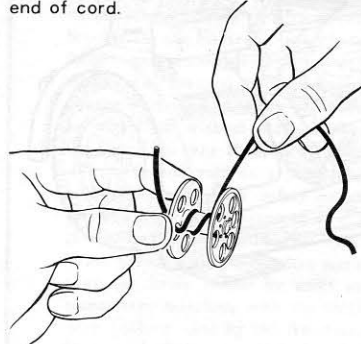

Widen hole of cord end putting pencil tip or some similar tool.

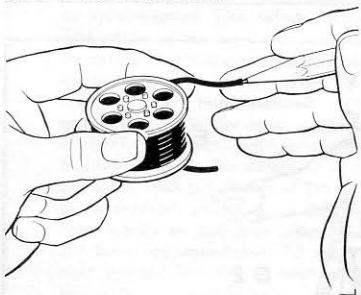

21 Installation of Gun Base onto Bogies

Fit gun base onto bogies with 3 mm screw as shown in the diagram. The below photo shows how bogies are fitted to gun base from which gun barrel and gun shield are temporarily removed.

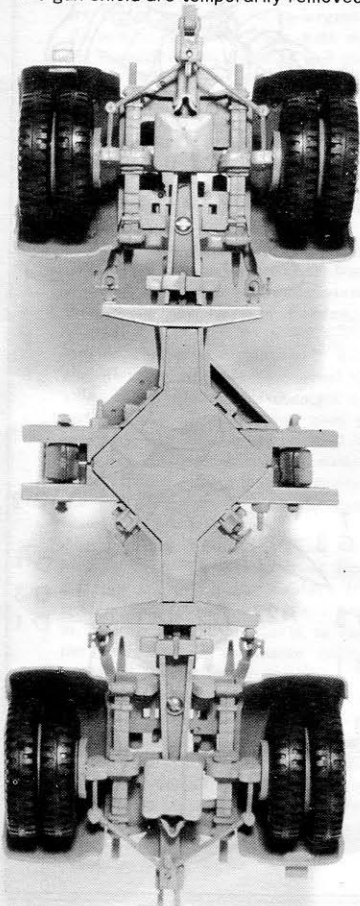

19 Installation of Upper Parts

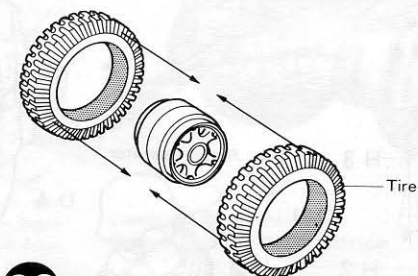
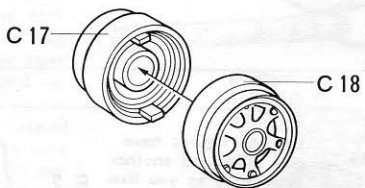
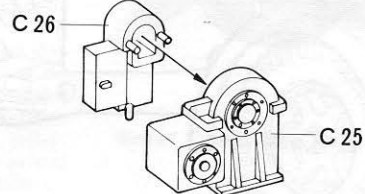
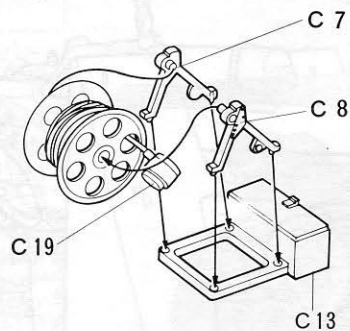

20 Installation of Tires

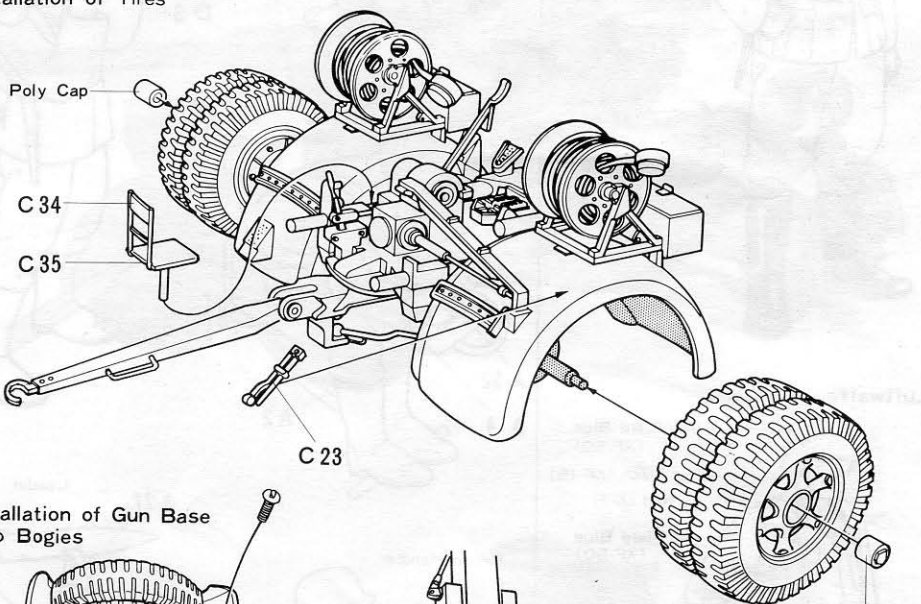

21 Installation of Gun Base onto Bogies

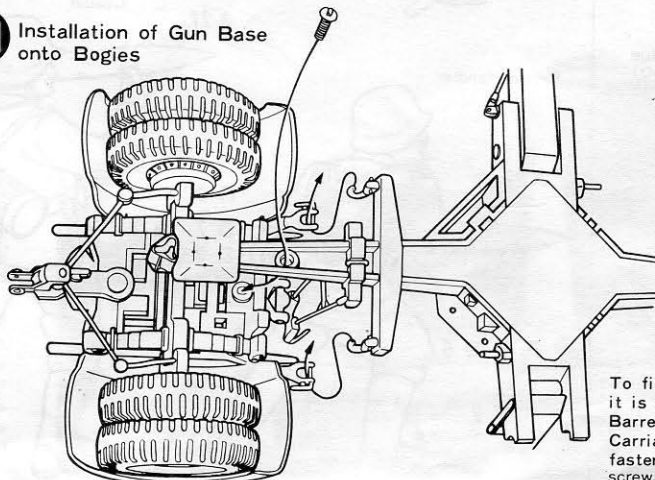

To fit Bottom Carriage onto Bogie, it is necessary first to remove Gun Barrel. First insert Hooks of Bottom Carriage into holes of an Bogie and then fasten Bottom Carriage on Bogie with screw.

22 Completion of 88 mm Gun

88 mm gun is able to fire even when fitted on bogies. In this case, right and left outriggers must be set open.

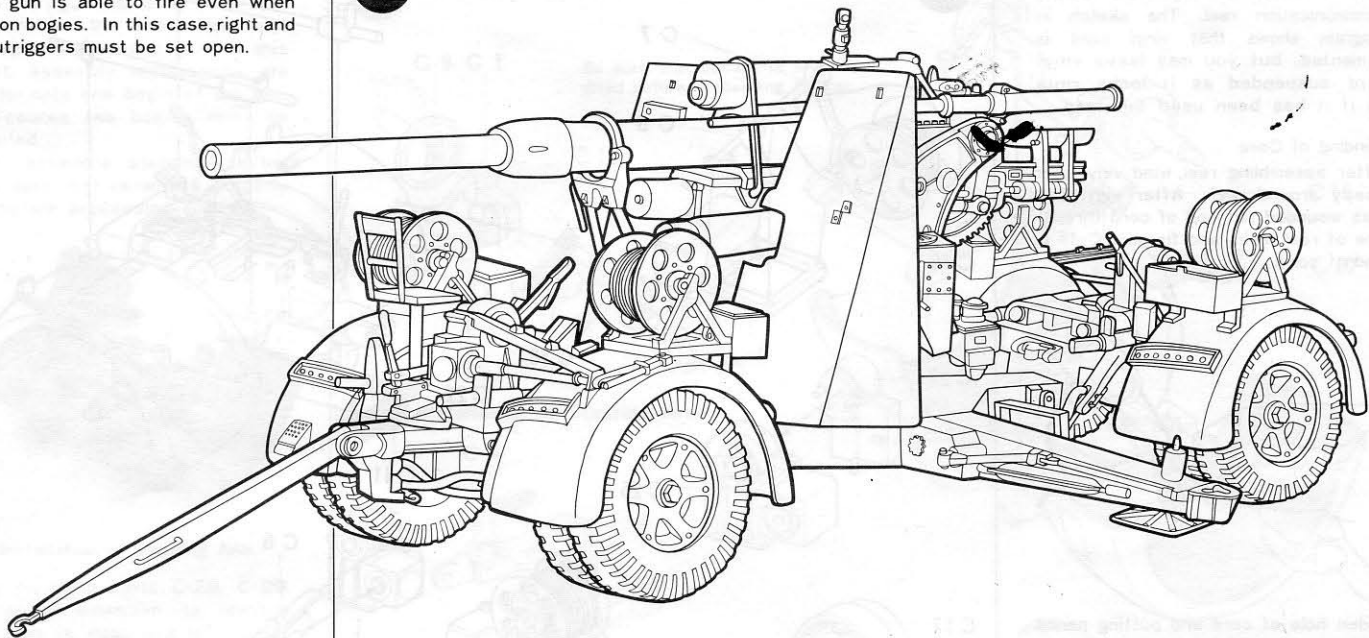

22 Completion of 88mm Gun

23 Assembly of Figure

Refer to the sketch well, and assemble various soldier figures. Correctly paint soldier figure in either one you prefer of the German Air Force or National Defense Army as shown below.

Reichswehr

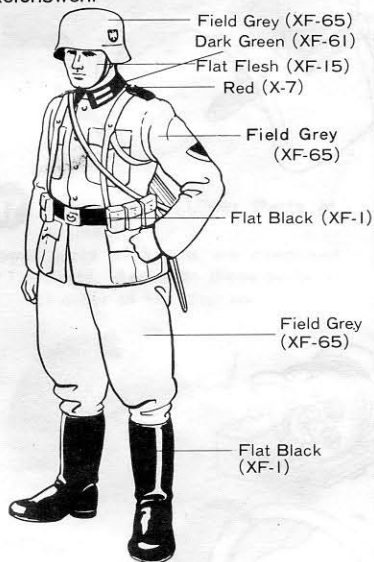

Luftwaffe

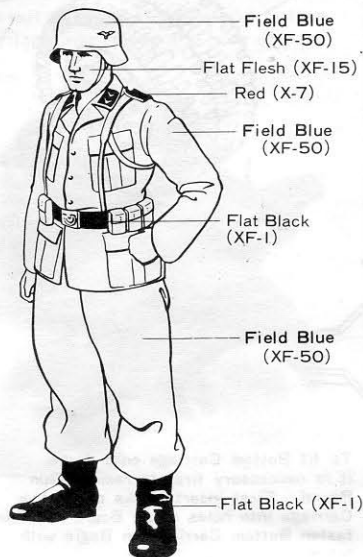

23 Assembly of Figures

Let the figures have Gas Mask and another accessories as you like.

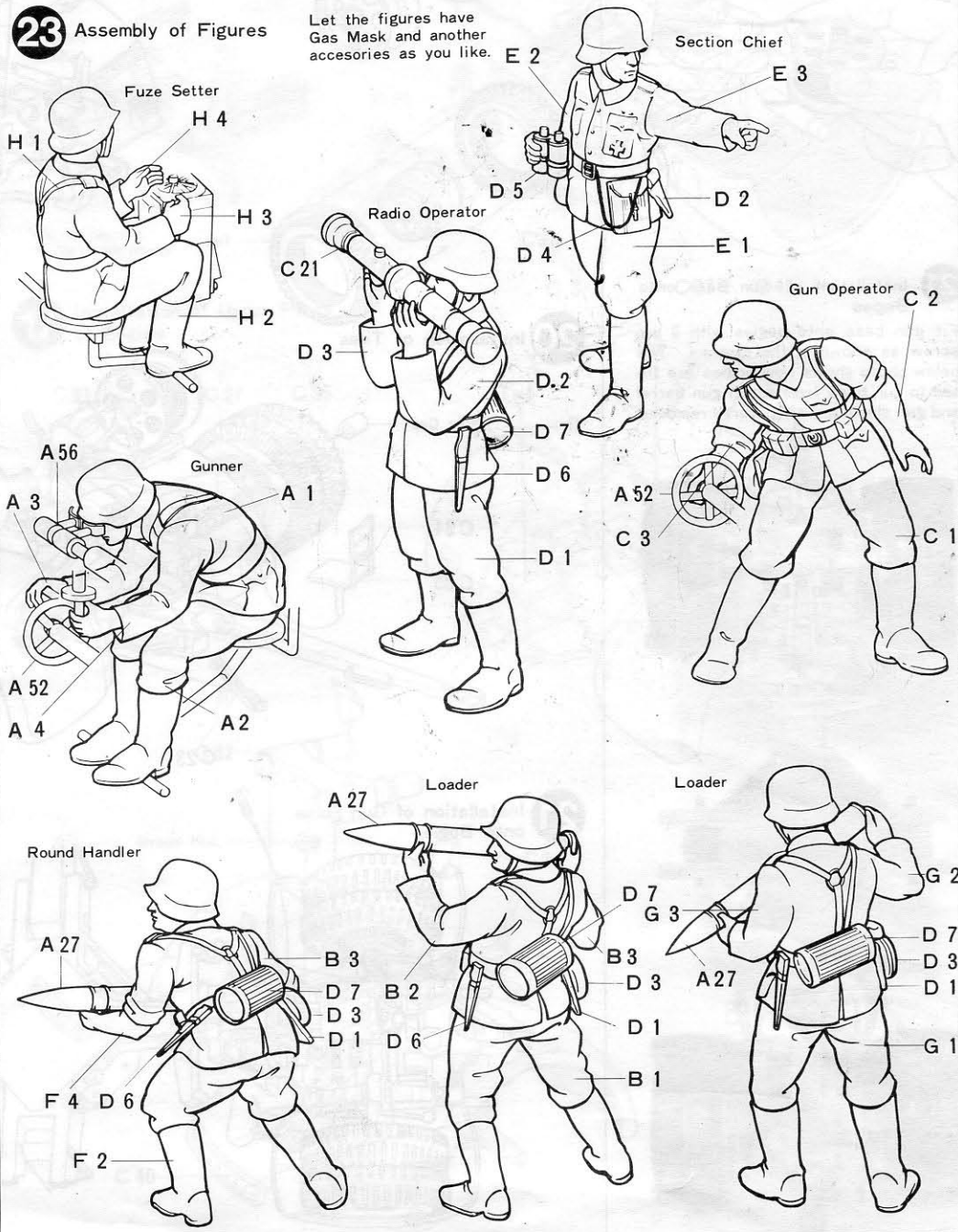

PAINTING

(Colour of German Fire Weapons)

From 1935 to February 1943, the colour that German fire weapon had to use was uniform grey with the exception of the combination of yellow and brown and the combination of grey and green which were used in Africa. Of course, they were all sober and mat. In 1942, the two combinations for use in Africa were replaced by brown. On the Eastern front where the Germans fought against the Russians, winter white (greyish white) was sprayed over the basic colour. The winter white was of water-paint type which could be wiped off without staining the basic colour. On 18th February 1943, all colours used till then were replaced with dark yellow by order of the authorities. We may safely say, therefore, that the basic colour of German fire weapons after the order (18th February) was dark yellow. Other colours seen thereafter were those painted over the basic colour by units in the field for camouflage matching with the battle area. Olive drab (colour used by the American forces), red brown (dark brown with a red tint) and dark yellow (formal colour). The three colours may be freely painted in large rough spots or lines or spray-painted. The colour continued until the last stage of the war.

In spring of 1945, appeared fire weapon painted in one colour, dark grey. This colour was seen also on heavy fire weapons including 88 mm guns allocated at the main points on the streets of Berlin to take defense against the Allied Forces' attack. The directive issued on February 18 in 1943 for change of basic colour applied to all vehicles and weapons that were delivered from works on and later than this date. All of the force on expedition did not change colour ever painted into this colour on and later than this date.

The camouflage shown in the right is only a few of patterns actually used. These few patterns did not applied to all the cases. The basic meaning of camouflage is how to conceal it from enemy. Then, its method should be a free choice. As one example, camouflage might have been done by spray painting with compressor even at the battle field if time permitted. On the other hand, camouflage might have been done only by brush or some other simple tool if at its urgent need due to its urgent mobilization. At some times, dirty body with mud after passing through muddy swamps had more camouflage effect than colour painting. This camouflage has the same meaning as insects such as ants and butterflies actually do by utilizing tree twigs, leaves, colours or shapes of plants to conceal themselves from enemies. Especially the German Forces had really advanced sense in study of camouflage effect. This applied not only to vehicles and fire weapons but also to camouflage cloths at its climax. The various camouflage cloths still now under study or development (use) in many countries originally stem all from the thought by the German Forces during World War II.

Beside camouflage painting, it was also one of the effective methods to conceal the object covering the whole with tree twigs or grass. This method was often adopted also to heavy fire weapons like 88 mm guns. But there are humorous episodes in records written by the then gunners that all twigs and grass they laid on the gun taking much time for camouflage were blown out by firing shock.

The painting method of using sand came into birth not on the Africa front first but on the Eastern front. On the Eastern front (Russia), leaves of the trees and grass begin to wither in September and it starts to make the lay of the land look in the same colour as that of withered leaves and grass.

Thus, this painting method was inevitably put into effect to conceal objects from enemy even in such a topography. Also on the Africa front, all the combats were battled not only in topography of desert. But the camouflage colour combination of Redbrown and Darkgreen was required in such topographies as Halfaya Pass or a mountain pass covered with steep sloped rocks or rocky walls.

Camouflage Painting of 88mm Gun in the Eastern Front

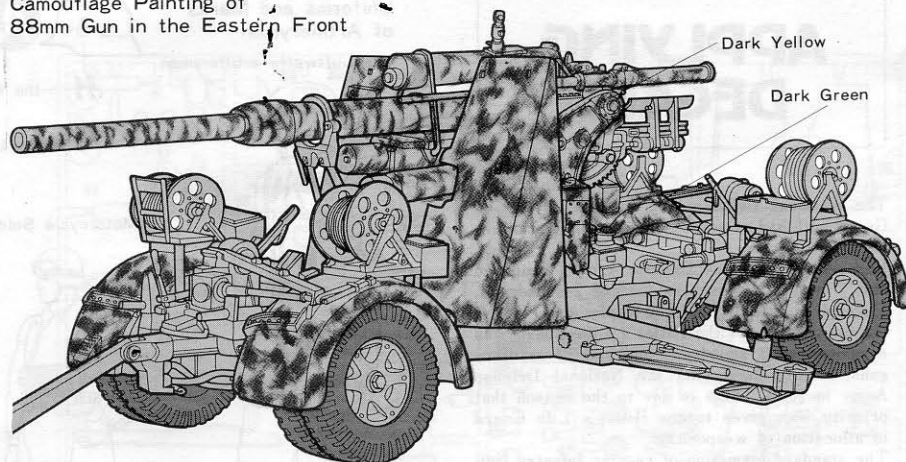

Winter Camouflage Painting

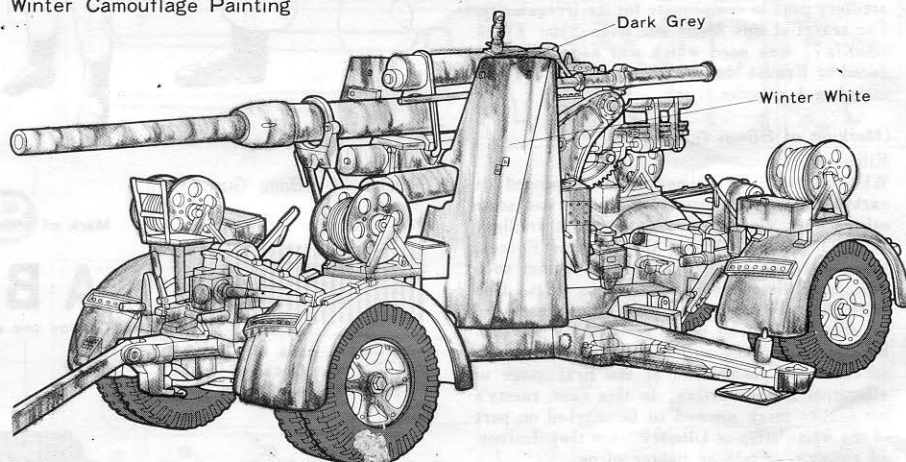

Camouflage Painting of 88mm Gun in North Africa

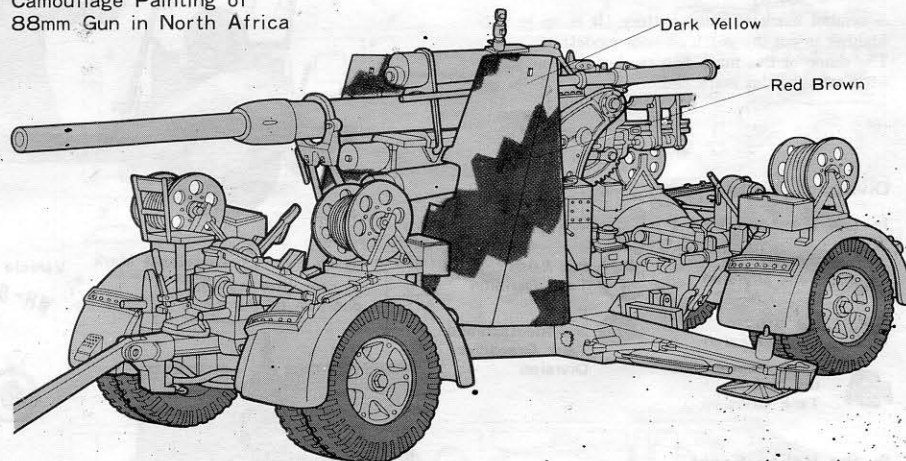

APPLYING DECALS

The National Defense Army and Hitler's Life Guard both had armoured unit having 1 artillery battalion.

In case of the National Defense Army's armoured unit, 1 battalion was composed of 2 squadrons. 1 squadron usually had 4 artillery guns.

On the other hand, the Hitler's Life Guard was composed of 3 squadrons and had 12 artillery guns, 4 more guns than the National Defense Army in total. This is due to the reason that priority was given to the Hitler's Life Guard in allocation of weapons.

The standard formation of regular Infantry Unit did not have 88 mm artillery guns. The irregular unit having 2 regiments only had 12 88 mm artillery guns to compensate for its irregularity. For travel of this 88mm gun, 8-ton Semi Track (SdKfz 7) was used which was especially produced by Krauss-Maffei. 1 squadron had 5 trucks including 1 reserve truck.

(Marking of 88mm Gun)

Killmark:

Whether to mark killmark quite depended on each battery. Some batteries did this and some others not. This seemed to be up to artillery soldiers' choice. Among the German Forces, there were no strict restrictions against such custom. Killmark was used in two ways. One is to show the numbers of planes they destroyed or shot down. The other is to show the numbers of planes they will destroy or shoot down to encourage themselves at the first stage of allocation to the battery. In this case, enemy's nationality mark seemed to be marked on part of the white strip of killmark when they destroyed enemy's vehicle or fighter plane.

(Symbol Mark)

A symbol mark of some battery (It is up to you whether to put this mark on your model). The shape of this mark is a cat but it is not clear what meaning this mark had.

Uniforms and Marks of Artillerymen

The Luftwaffe artilleryman

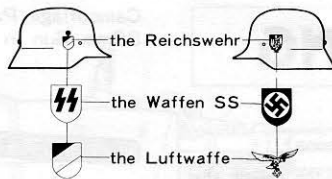

The Reichswehr artilleryman

Motorcycle Soldier



SS artilleryman



Marks of 88mm Gun

Kill Mark



In case of Flak 37, cut Decal in length of Gun Barrel.

Mark of shooting position

A · B · C · D

Choose one mark and apply it.

Symbol Mark

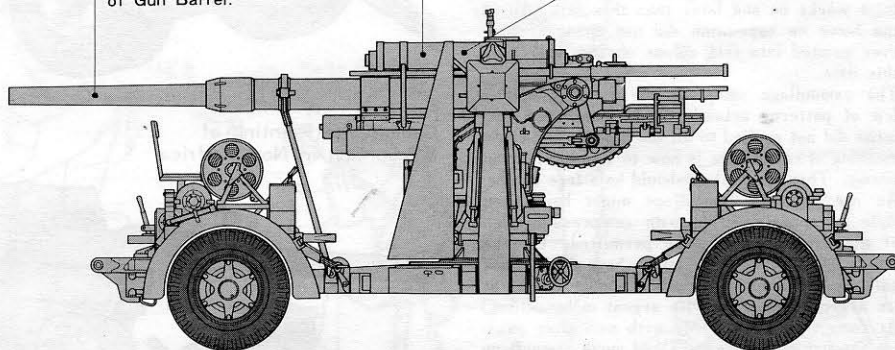

Divisional Marks

In the Eastern Front

the 4th Tank Division

the 5th Tank Division

the 3rd Tank Division

the 24th Tank Division

the Groβdeutschland Tank Grenadier Division

In the Italian Front

the Luftwaffe the Hermannering Air-borne Panzer Division

In the Normandy

the 1st SS Tank Division

the 9th SS Tank Division

the 12th SS Tank Division

In the North Africa

the 15th Tank Division

the 21st Tank Division

Symbol of the Afrika Korps The 15th and the 21st Tank Division under the command of General Rommel fought in North Africa.

Mark of the Afrika Korps

Divisional Mark

In rear, the marking position is the same.

Vehicle Number

WH-99120

Vehicle Number

WH 99120

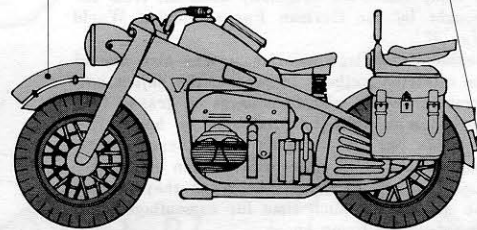
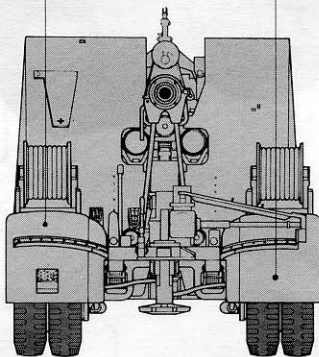

Marks of 8 ton Semi Track

(Divisional Mark) (Tactical Mark)

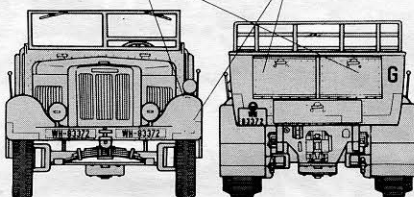

(Tactical mark)

The 8-ton semi track to pull 88 mm gun obviously had the same marks as those on 88 mm gun. This truck had the below tactical mark when pulling 88 mm gun. This mark shows artillery battalion.

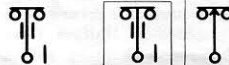

This mark was used in and after 1943 in place of the mark at left. Company Number

PARTS

A PARTS

- 1. Gun Barrel (Left) 2. Gun Barrel (Right)
- 3. Cradle (Left) 4. Cradle (Right)
- 5. Automatic Rammer (A)
- 6. Equibrator (A) 7. Equibrator (B)
- 8. Locking Collar-Flak 37
- 9. Fuze Setter Part A · Flak 37
- 10. Recuperator Cylinder (Left)
- 11. Recuperator Cylinder (Right)
- 12. Recoil Cylinder Head
- 13. Automatic Rammer (B)
- 14. Equibrator Part (A)
- 15. Recuperator Cylinder Holder
- 16. Top Carriage (Left)
- 17. Top Carriage (Right)
- 18. Equibrator Arm
- 19. Equibrator Part (B)
- 20. Main Box Plate
- 21. Cartridge Case
- 22. Elevation Gear
- 23. Breechblock
- 24. Breech
- 25. Cum
- 26. Locking Collar · Flak 36
- 27. Round
- 28. Fuze Setter Part (B)
- 29. Cradle Part (A)
- 30. Recuperator Cylinder Head
- 31. Fuze Setter Part (C)
- 32. Fuze Setter Part (D)
- 33. Elevation Operating Handle
- 34. Recuperator Cylinder Bottom
- 35. Direct Sight Bracket
- 36. Shield Stay
- 37. Recuperator Cylinder Piston
- 38. Elevation Gear Part
- 39. Stay (A)
- 40. Stay (B)
- 41. Seat Stay Part (A)
- 42. Elevation Gear (B)
- 43. Cradle Part (B)
- 44. Indicator
- 45. Meter Box (A) · Flak 37
- 46. Meter Box (B) · Flak 37
- 47. Handwheel Holder
- 48. Equibrator Part (C)
- 49. Meter Panel
- 50. Battery Case (A) · Flak 36
- 51. Battery Case (B) · Flak 36
- 52. Handwheel
- 53. Loading Tray Hinge (A)
- 54. Seat
- 55. Loading Tray Hinge (B)
- 56. Telescopic Sight
- 57. Elevation Indicator
- 58. Battery Case (C) · Flak 36
- 59. Loading Tray Part (A)
- 60. Loading Tray Part (B)
- 61. Seat Stay Part (B)
- 62. Breechblock Lever
- 63. Battery Case (D) · Flak 36
- 64. Shield Slit Lever
- 65. Fuze Setter Part (E)
- 66. Fuze Setter Part (F)
- 67. Fuze Setter Part (G)
- 68. Slit Shutter
- 69. Pedestal
- 70. Top Carriage Mount
- 71. Loading Tray
- 72. Equibrator Stay
- 73. Fuze Setter · Flak 37
- 74. Battery Case · Flak 37
- 75. Pedestal Bottom
- 76. Shield

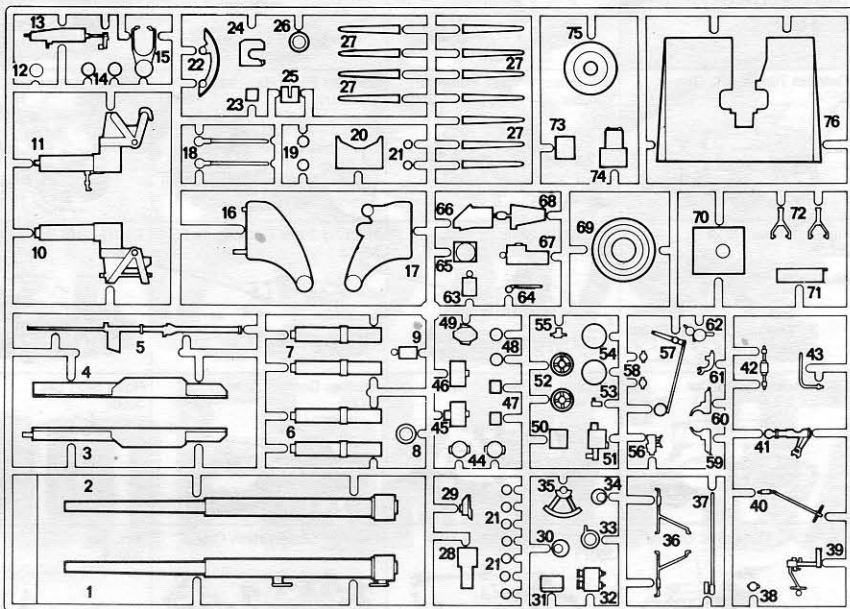

B PARTS

- 1. Leveling Jack
- 2. Gun Travel Lock
- 3. Tool Box
- 4. Stake Guid
- 5. Stake
- 6. Outrigger Locking Arm
- 7. Outrigger Locking Pin
- 8. Meter Box Cover
- 9. Outrigger (A)
- 10. Outrigger (B)
- 11. Pedestal Leveling (A)
- 12. Pedestal Leveling (B)
- 13. Pedestal Leveling Handwheel
- 14. Jack Pad
- 15. Gun Travel Lock Support (Left)
- 16. Gun Travel Lock Support (Right)
- 17. Locking Bar
- 18. Outrigger Part
- 19. Outrigger Holder (A)
- 20. Outrigger Holder (B)
- 21. Bottom Plate
- 22. Connecting Hook
- 23. Bottom Carriage
- 24. Meter Panel
- 25. Gun Travel Lock (B)
- 26. Driver Seat
- 27. Box
- 28. Frame
- 29. Front Tire
- 30. Rear Seat
- 31. Cylinder (Right-A)
- 32. Cylinder (Left-A)
- 33. Engine (Left)
- 34. Handle Bar
- 35. Battery
- 36. Fork Top Bridge
- 37. Kick Pedal
- 38. Side Bag
- 39. Number Plate
- 40. Stand
- 41. Fork Bridge
- 42. Side Bag Holder
- 43. Front Fork (Left)
- 44. Front Fork (Right)
- 45. Cylinder (Right-B)
- 46. Cylinder (Left-B)
- 47. Spring
- 48. Helmet
- 49. Goggle
- 50. Cartridge Case Bottom
- 51. Round Container Cover
- 52. Engine (Right)
- 53. Frame
- 54. Exhaust Pipe
- 55. Muffler
- 56. Drive Shaft
- 57. Engine Front Part
- 58. Headlight Cover
- 59. Headlight
- 60. Rear Grip
- 61. Horn
- 62. Fuel Tank Cap
- 63. Rifle KAR 98K
- 64. Round Container (A · Upper)
- 65. Round Container (A · Lower)
- 66. Round Container (B · Lower)
- 67. Round Container (B · Upper)
- 68. Gas Mask Case
- 69. Binoculars

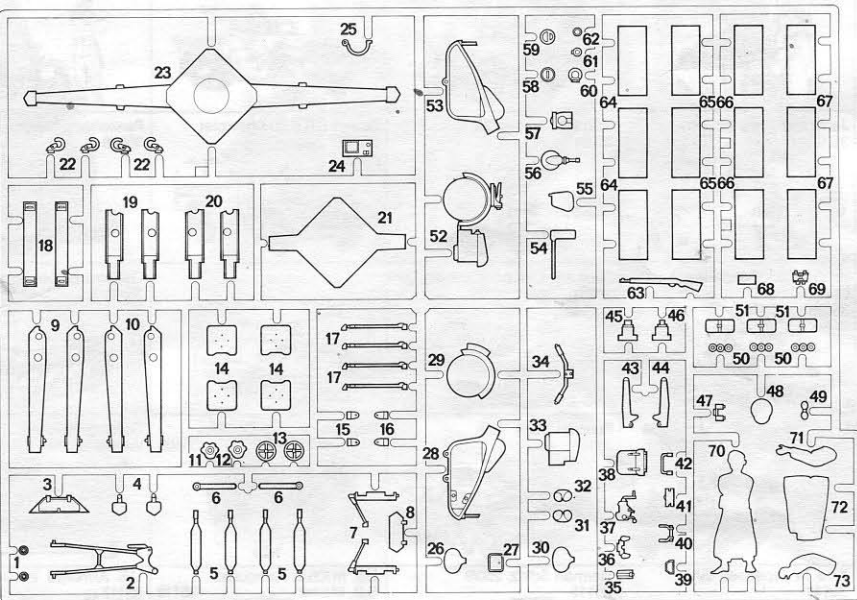

C PARTS

- 1. Upright (Left)
- 2. Upright (Right)
- 3. Lever
- 4. Connecting Rod Receptacle (Left)
- 5. Connecting Rod Receptacle (Right)
- 6. Winch Shaft
- 7. Reel Support (Left)
- 8. Reel Support (Right)
- 9. Wheel Shaft
- 10. Spring (Right)
- 11. Spring (Left)
- 12. Hammer
- 13. Tool Box
- 14. Reel (A)
- 15. Reel (B)
- 16. Track Rod
- 17. Wheel (Inner)
- 18. Wheel (Outer)
- 19. Cable Parts
- 20. Shovel
- 21. Range Finder
- 22. Step (A)
- 23. Winch Lever
- 24. Step (B)
- 25. Winch Motor (A)
- 26. Winch Motor (B)
- 27. Bottom Carriage Receptacle
- 28. Steering Arm (Right)
- 29. Steering Arm (Left)
- 30. Step (C)
- 31. Connecting Hook Part
- 32. Cylinder
- 33. Connecting Rod
- 34. Seat Back
- 35. Seat
- 36. Hook
- 37. Hand Brake Lever
- 38. Fender Support Arm (A)
- 39. Fender Support Arm (B)
- 40. Fender Support Arm (C)
- 41. Fender Support Arm (D)
- 42. Bumper
- 43. Bogie Stopper (A)
- 44. Bogie Stopper (B)

